

INSTALLATION

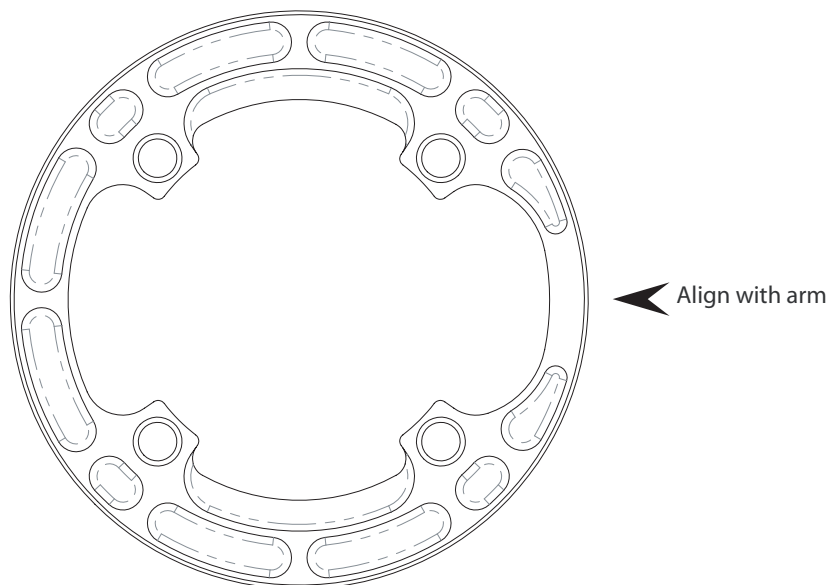

1. Make sure you are using the correct size bash ring for your chainring size.
2. Install the bash ring on the outside of the crankset spider
2. Align the quadrant of the bash ring with the smallest height with the crank arm.
3. Install the chainring bolts. Make sure the chainring bolts are the correct length to ensure enough thread engagement or not too long which could prevent proper tightening. In a cross pattern, tighten the 4 chainring bolts to manufacturer recommended torque (usually 10-12 N.m for steel chainring bolts).
4. Make sure the bash ring seats perfectly flush to the spider. There should be no play at all. If there is any, it is very likely that the chainring bolts used are too long.

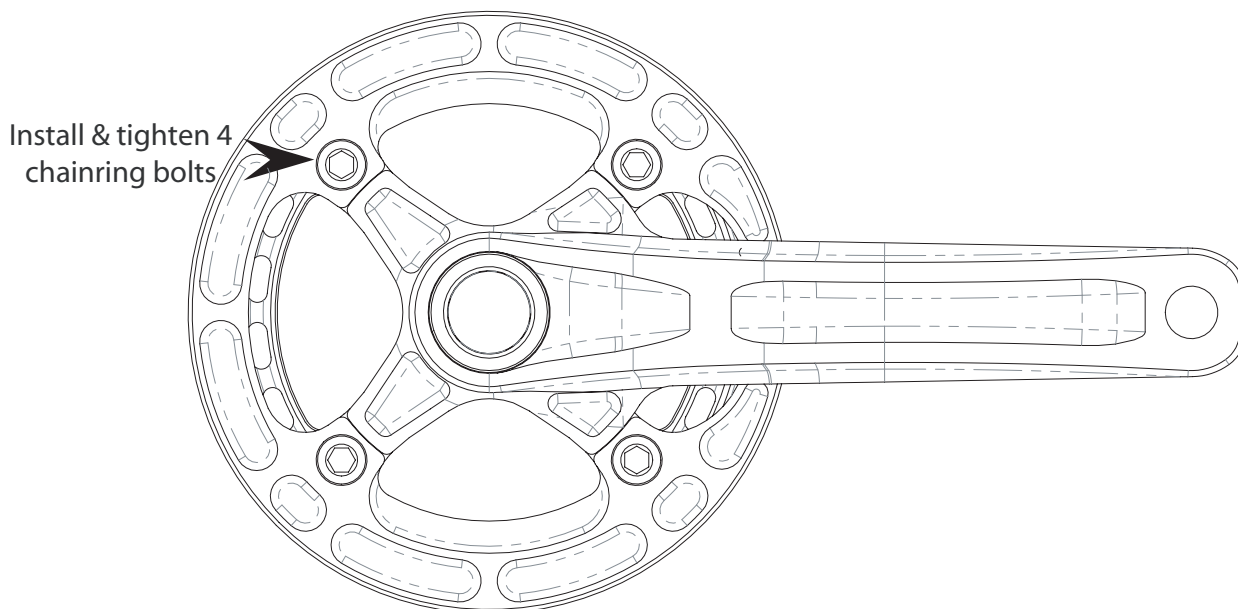

WARRANTY

All Hope Technology components are covered for two years from original date of purchase against manufacturer defects in material and workmanship.

Proof of purchase is required. Products must be returned to the original place of purchase or to Hope Technology to process any warranty claim.

Please print and fill the "goods returned form" found on the tech support section of our website should you wish to send a product back.

This warranty does not cover any damage caused through normal wear, mis-use or failing to comply by the recommendations given.

This warranty does not affect your statutory rights.