

40T-REx SH

Compatible with:
Shimano XTR CS-M980 11-36
Shimano XT CS-M771-10 11-36



40T-REx SR

Compatible with:
SRAM X5 PG-1030 11-36
SRAM X7 PG-1050 11-36
SRAM X9 PG-1070 11-36

Outer (drive-side) face shown

FITTING INSTRUCTIONS

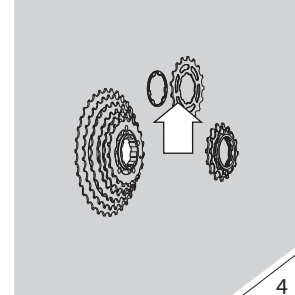
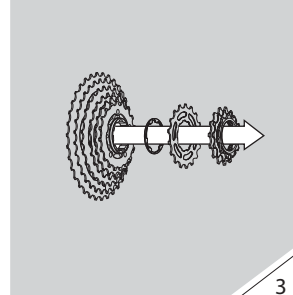
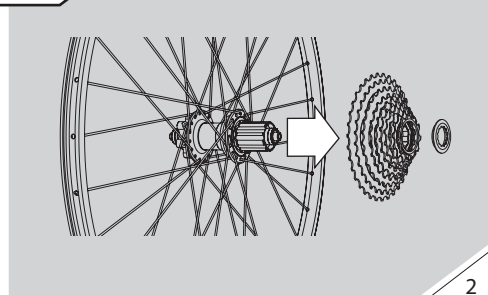
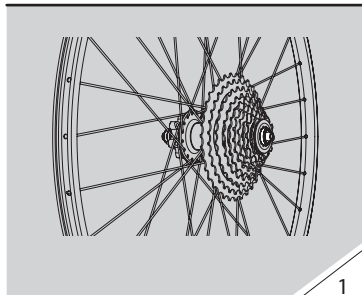

Before you start, ensure that your rear derailleurs has sufficient tooth capacity to cover the increased range of gears (see note 1) and that you have a compatible 10 speed cassette.

Unscrew the lock ring and remove existing 10 speed cassette from freehub. If you are adapting a cassette that has previously been used ensure all sprockets and spacers are fully cleaned prior to re-assembly.

Separate the individual sprockets whilst being careful to keep any spacers in their intended locations.

Remove the individual sprocket that you wish to discard from the cassette and the adjacent spacer (see note 2).

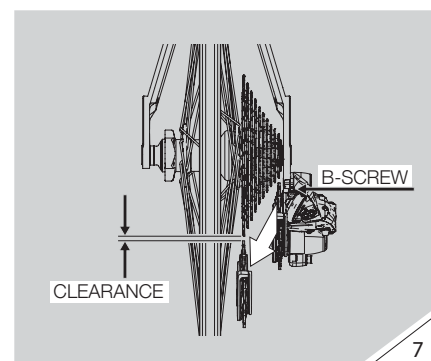
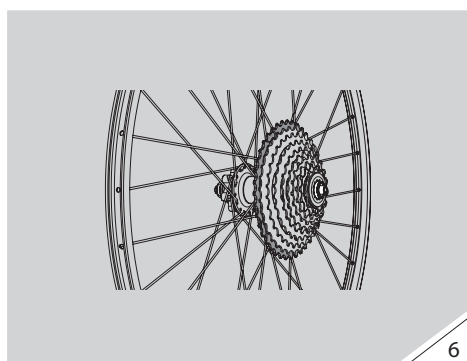
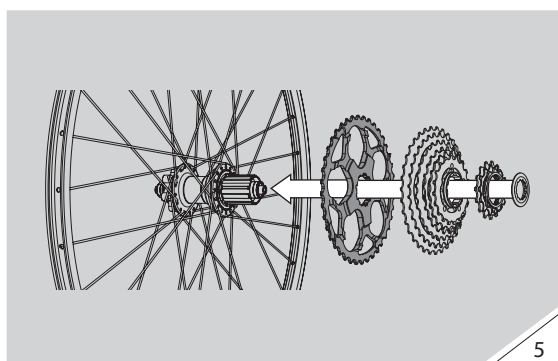

Slide the 40T-REx sprocket onto the freehub taking note of the spline location. No additional spacers are required.

Assemble the existing cassette (minus one sprocket) onto the freehub. Fit the lock ring and tighten to the manufacturers recommended tightening torque.

With the chain on the 40T-REx sprocket, adjust the B-tension adjustment screw on your rear derailleur so that the top guide pulley sits close to the 40T-REx but doesn't touch it (see note 3). Ensure that your chain is of sufficient length to cover the increased range of gears (see note 4). Finally, shift through the full range of gears whilst turning the pedals to check that there are no problems. Your 10 speed cassette with expanded ratio is now ready to ride.

Note 1: For a 1 x 10 set-up with a newly converted 11-40 cassette you will need a rear derailleur with a 29T capacity [40-11=29].

Note 2: In most cases we recommend removing the 17T sprocket. In the case of the Shimano CS-M980 and CS-M771-10 this is the only sprocket that can be easily removed. In the case of the SRAM PG-1030, PG-1050 and PG-1070 it is possible to remove alternative individual sprockets.

Note 3: If your B-tension screw is not long enough use the supplied M4 x 20mm screw. Refer to the manufacturer's instructions for further guidelines on adjusting your rear derailleur.

Note 4: With the chain mounted on your largest front chainring and the 40T-REx sprocket, check that your chain is not being pulled tight. If your chain is not long enough, replace it with a new longer one.